

General Safety Information

WARNING

- To avoid serious injuries:
 - Obtain and read the service instructions carefully prior to installing the parts. Loose, worn, or damaged parts may cause serious injury to the rider. We strongly recommend only using genuine Shimano replacement parts.
 - It is important to completely understand the operation of your bicycle's brake system. Improper use of your bicycle's brake system may result in a loss of control or an accident, which could lead to severe injury. Because each bicycle may handle differently, be sure to learn the proper braking technique (including brake lever pressure and bicycle control characteristics) and operation of your bicycle. This can be done by consulting your professional bicycle dealer and the bicycle's owners manual, and by practicing your riding and braking technique.
 - These brake levers are equipped with a mode switching mechanism to make them compatible with cantilever brakes and Roller Brakes or V-Brakes with power modulator.
- If the incorrect mode is selected it may cause either excessive or insufficient braking force to occur, which could result in dangerous accidents.**
- Be sure to select the mode in accordance with the instructions given in the table below.**

Mode position	Applicable brake
---------------	------------------

C/R position

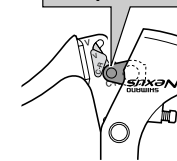

- Cantilever brakes
- Roller Brakes

The C indicates the mode position for compatibility with cantilever brakes.

The R indicates the mode position for compatibility with Roller Brakes.

V position

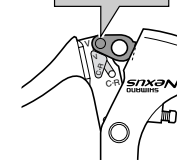

- V-Brakes with power modulator

The V indicates the mode position for compatibility with V-Brakes with power modulator.

Use the brake levers with mode switching mechanism in the combinations given above.

- Read these Technical Service Instructions carefully, and keep them in a safe place for later reference.

CAUTION

- To avoid serious injuries:
- Be sure to shift the lever one gear at a time, and reduce the force being applied to the pedals during shifting. If you try to force operation of the shifting lever while the pedals are being turned strongly, your feet may come off the pedals and the bicycle may topple over, which could result in serious injury.

NOTE:

- For maximum performance we highly recommend Shimano lubricants and maintenance products.
- Parts are not guaranteed against natural wear or deterioration resulting from normal use.

SI-6J30A

SB-8S20 Revo-shift Lever
BL-IM60 Brake Lever
CJ-8S20 Cassette Joint

Technical Service Instructions



Be sure to read these service instructions in conjunction with the service instructions for the Inter-8 hub before use.

Revo-shift lever operation

Turn the Revo-shift lever to shift to each of the eight gears.

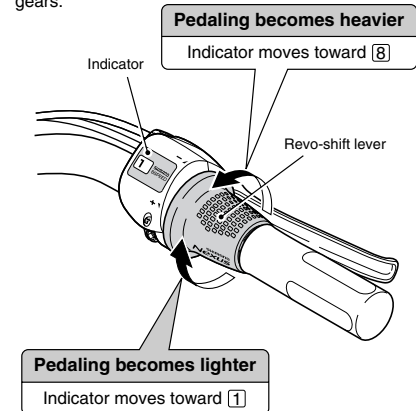

Installation of the lever

Install the lever as shown in the illustration.

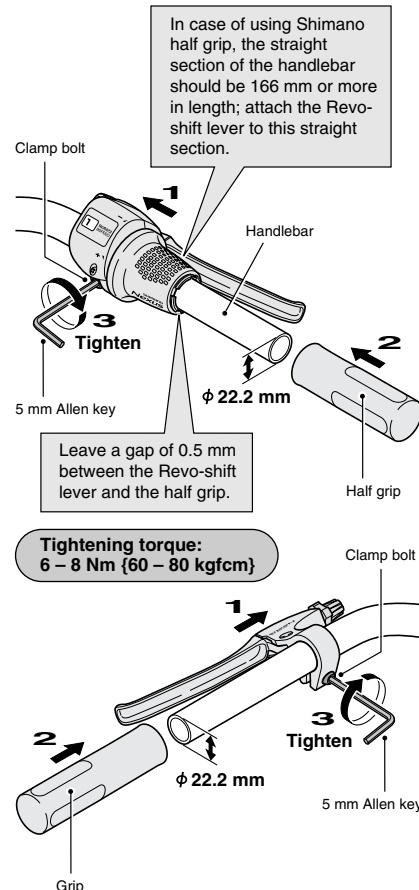

Disconnecting the shifting cable when removing the rear wheel from the frame.

Disconnect the cable from the cassette joint when removing the rear wheel from the frame.

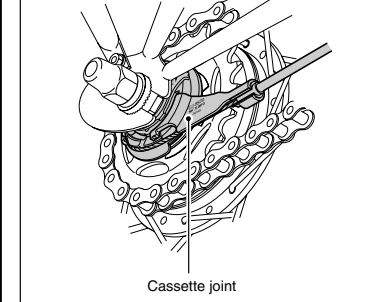

1. Set the Revo-shift lever to 1.

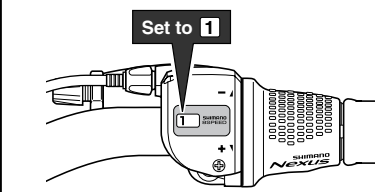

2. Pull the outer casing out from the outer casing holder of the cassette joint, and then remove the inner cable from the slit in the bracket.

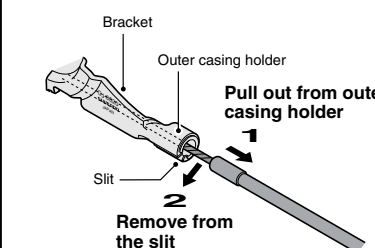

3. Remove the inner cable fixing bolt unit from the cassette joint pulley.

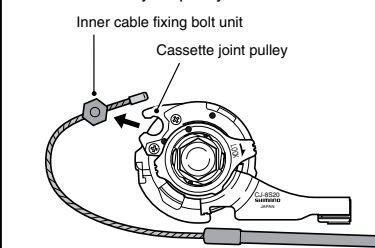

If it is difficult to pull the outer casing out from the outer casing holder of the cassette joint, insert a 2 mm Allen key or a #14 spoke into the hole in the cassette joint pulley, and then turn the pulley to loosen the inner cable. Then remove the inner cable fixing bolt unit from the pulley first, and after this remove the outer casing from the outer casing holder.

2. Remove the inner cable fixing bolt unit
3. Pull out from the outer casing holder

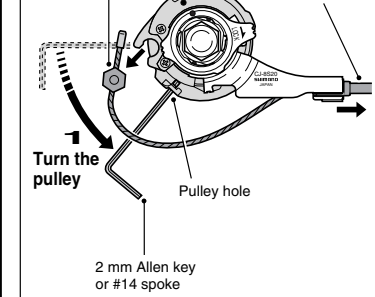

Note:
If reusing the cable, refer to steps 7 to 9 in "Installation of the shifting cable".

Installation of the shifting cable

Use a shifting cable with one inner cable drum.
Cable with one inner cable drum / SIS-SP40 (4 mm dia.)

1. Set the Revo-shift lever to 1.

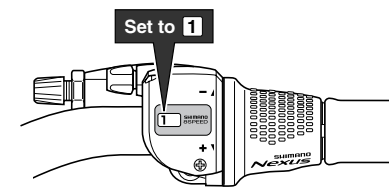

Revo-shift lever side

2. Loosen the cover fixing screw, and then remove the upper cover.

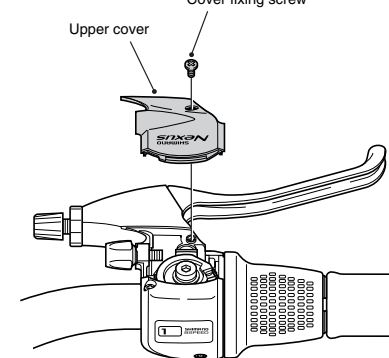

3. Pass the inner cable through the hole in the cable adjustment bolt. Next, hook the inner cable into the groove of the pulley, and pull the inner cable so that the inner cable drum fits into the hole in the pulley.

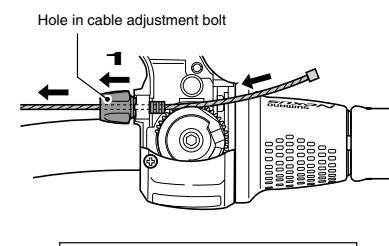

4. Replace the upper cover and tighten the cover fixing screw.

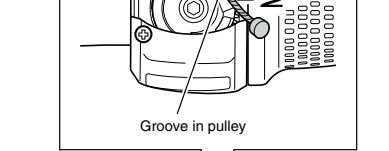

5. Pass the inner cable through the SIS-SP40 outer casing through the end with the plastic cap.

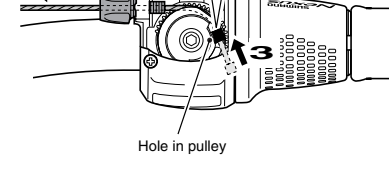

6. After checking that the end of the outer casing is sitting securely in the cable adjustment bolt of the Revo-shift lever, attach the inner cable fixing bolt unit to the inner cable.

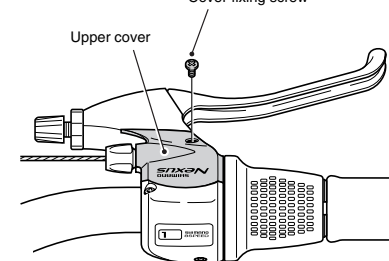

7. Bring the cable around to the cassette joint pulley, hold so that the inner cable fixing nut is facing to the outside (toward the fork end), and then slide the flats part of the inner cable fixing washer into the gap in the pulley.

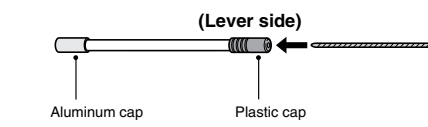

If cutting the outer casing, cut it near the end with the plastic cap while the cap is still attached. Then make the cut end perfectly round and attach the plastic cap.

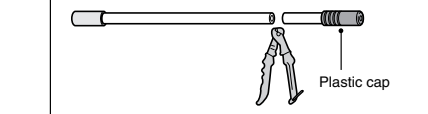

Remove the plastic cap.

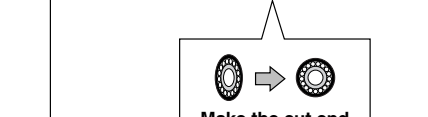

Make the cut end perfectly round.

Attach the plastic cap.

Cassette joint side

6. After checking that the end of the outer casing is sitting securely in the cable adjustment bolt of the Revo-shift lever, attach the inner cable fixing bolt unit to the inner cable.

Inner cable fixing bolt unit
Note: Do not use this inner cable fixing bolt unit with the CJ-4S30 cassette joint.

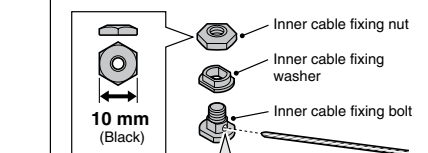

Pass the inner cable through the hole.

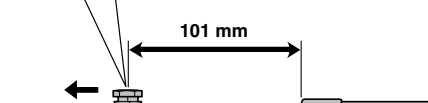

101 mm

Pull the inner cable while attaching the inner cable fixing bolt unit.

Tightening torque:
4 - 6 Nm (40 - 60 kgfcm)

7. Bring the cable around to the cassette joint pulley, hold so that the inner cable fixing nut is facing to the outside (toward the fork end), and then slide the flats part of the inner cable fixing washer into the gap in the pulley.

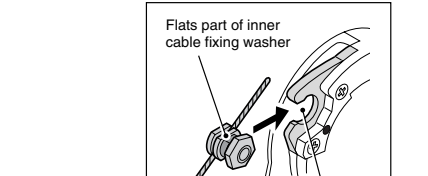
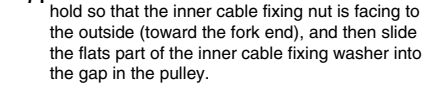

8. Turn the cable 60° counterclockwise and attach it to the hook.

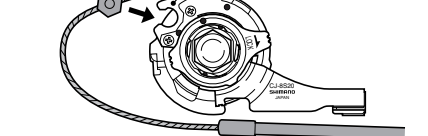
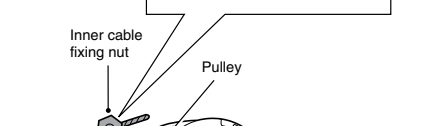

9. Attach the inner cable to the pulley as shown in the illustration, pass the inner cable through the slit in the cassette joint bracket, and then insert the end of the outer casing securely into the outer casing holder.

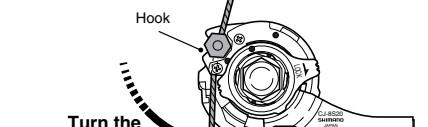

Turn the cable 60°

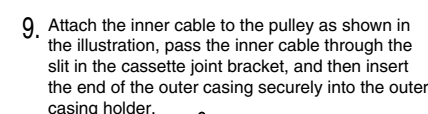

Insert into the outer casing holder.



Pass through the slit.

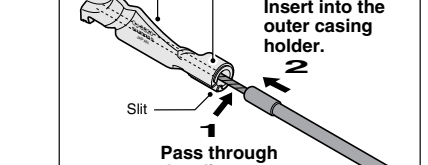
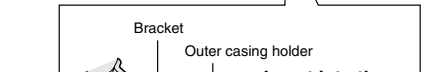

If first inserting the outer casing into the outer casing holder is easier, then first insert the outer casing into the outer casing holder, and then insert a 2 mm Allen key or a #14 spoke into the hole in the cassette joint pulley, and then turn the pulley so that the inner cable fixing bolt unit fits into the gap in the pulley.

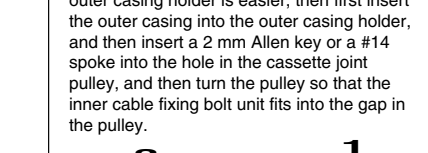

Insert the inner cable fixing bolt unit

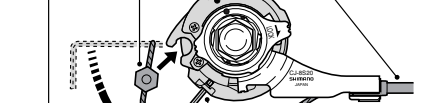

101 mm

Turn the pulley

2 mm Allen key or #14 spoke

10. Secure the cable to the frame with the outer casing bands.

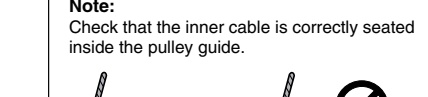

Note:
Check that the inner cable is correctly seated inside the pulley guide.

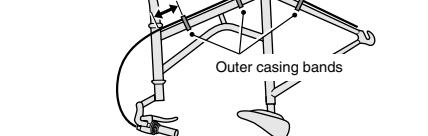
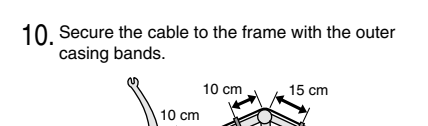
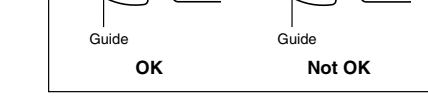

Adjusting the cassette joint

1. Set the Revo-shift lever to 4. Check to be sure that the yellow setting lines on the cassette joint bracket and pulley are aligned at this time.

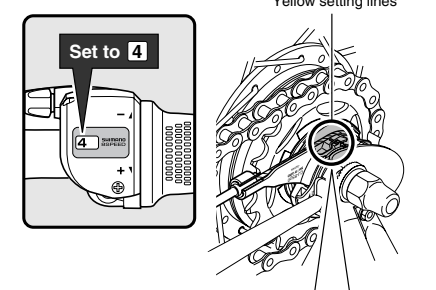

The yellow setting lines on the cassette joint are located in two places. Use the one that is easiest to see.

When bicycle is standing up

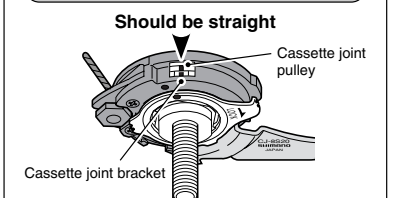

When bicycle is upside down

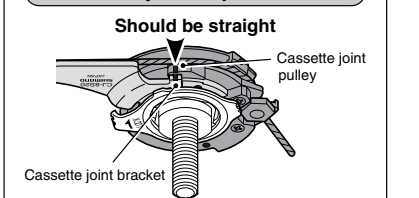

If the yellow setting lines are not aligned, turn the cable adjustment bolt of the Revo-shift lever to align the setting lines. After this, move the Revo-shift lever once more from 4 to 1 and then back to 4, and then re-check to be sure that the yellow setting lines are aligned.

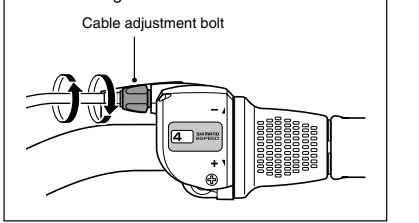

2. After adjusting the cassette joint, cut off the excess length of inner cable and then install the inner end cap.

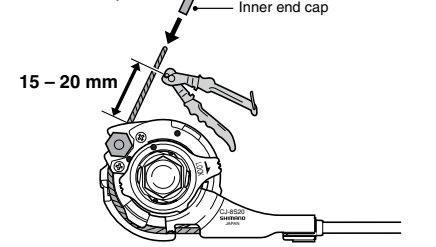

These service instructions explain how to use and maintain the Shimano bicycle parts which have been used on your new bicycle. For any questions regarding your bicycle or other matters which are not related to Shimano parts, please contact the place of purchase or the bicycle manufacturer.

These service instructions are printed on recycled paper. Please note: Specifications are subject to change for improvement without notice. (English)

SHIMANO
SHIMANO AMERICAN CORPORATION
One Holland Irvine CA 92618 U.S.A. Phone 949-951-5003
SHIMANO EUROPA
Industrieweg 24 NL-8071 CT Nunspeet, Holland Phone 31-341-272222
SHIMANO INC.
3-77 Oimatsucho, Sakai, Osaka, Japan Phone 072-223-3243