

General Safety Information

WARNING

– To avoid serious injuries:

- Obtain and read the service instructions carefully prior to installing the parts. Loose, worn, or damaged parts may cause serious injury to the rider. We strongly recommend only using genuine Shimano replacement parts.
- Read these Technical Service Instructions carefully, and keep them in a safe place for later reference.

CAUTION

– To avoid serious injuries:

- Be sure to shift the lever one gear at a time, and reduce the force being applied to the pedals during shifting. If you try to force operation of the shifting lever while the pedals are being turned strongly, your feet may come off the pedals and the bicycle may topple over, which could result in serious injury.
- Never place your foot on the bell crank. Doing so may cause problems with gear shifting.

NOTE:

- For maximum performance we highly recommend Shimano lubricants and maintenance products.
- Parts are not guaranteed against natural wear or deterioration resulting from normal use.

SI-6NL0A-001

SL-3S41-E
SL-3S42-E
SM-BC06

Revo-shift Lever

Bell Crank 6

Technical Service Instructions

Be sure to read these technical service instructions in conjunction with the technical service instructions for the Inter-3 hub.

Revo-shift lever operation

Turn the Revo-shift lever to shift to each of the three gears.

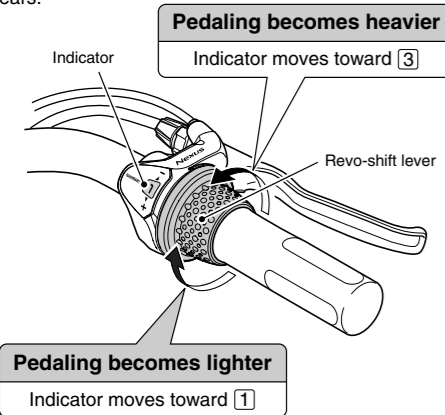

- ① Starting/Riding on sandy or rough road surfaces/Riding up slopes/Carrying heavy loads/Riding into head winds/When the light is illuminated
- ② Riding on flat road surfaces
- ③ Riding at high speeds

Installation of the lever

Install the lever as shown in the illustration.

Use a brake lever band with a thickness of 4.3 mm or less so that it does not obstruct the brake lever and the Revo-shift lever.

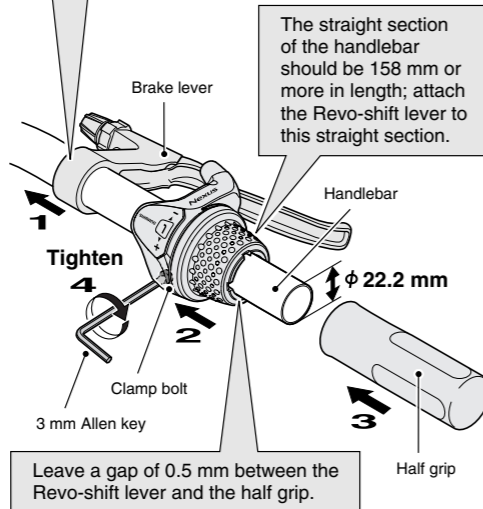

Tightening torque:
2 – 2.5 N·m {20 – 25 kgf·cm}

Installation of the shifting cable

Use a shifting cable with one inner cable drum.

SIS-SP40 (4 mm dia.)

1. Set the Revo-shift lever to ①.

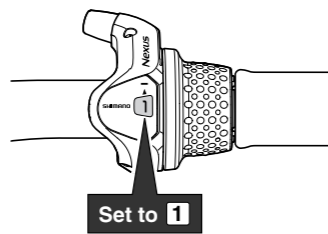

Revo-shift lever side

2. Loosen the two cover fixing screws, and then remove the cover.

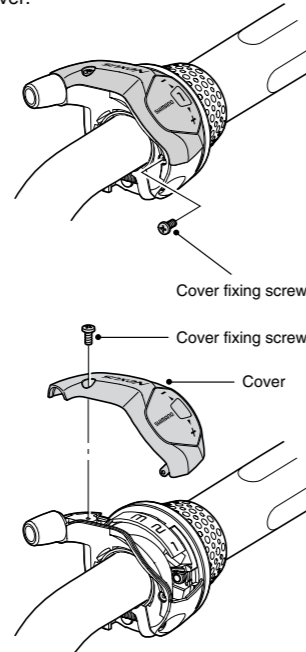

3. Pass the inner cable from the hole in the winder unit through the hole in the outer casing holder. Next, insert the inner cable into the groove of the cable guide.

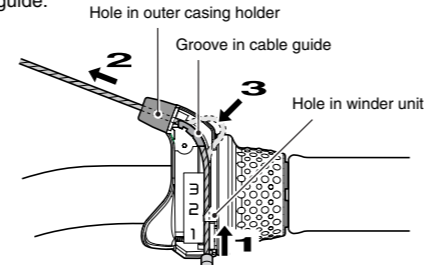

4. Pull the inner cable so that the inner cable drum fits into the recess in the winder unit.

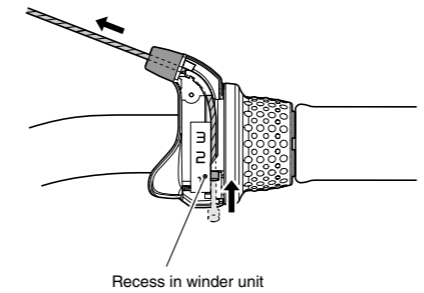

5. Insert the outer casing into the outer casing holder.

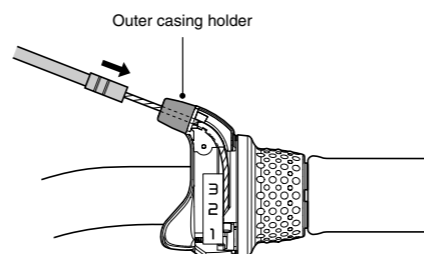

6. Replace the cover and tighten the two cover fixing screws.

Tightening torque:
0.1 – 0.2 N·m {1 – 2 kgf·cm}

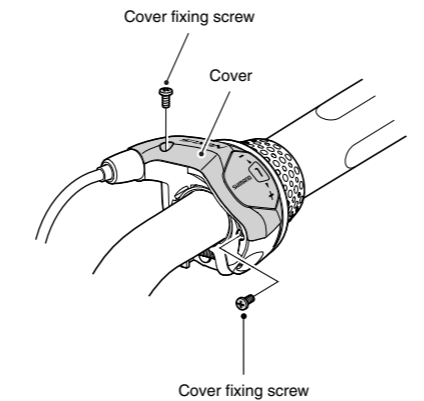

Bell crank side

7. Loosen the cover fixing screw, and then remove the bell crank cover.

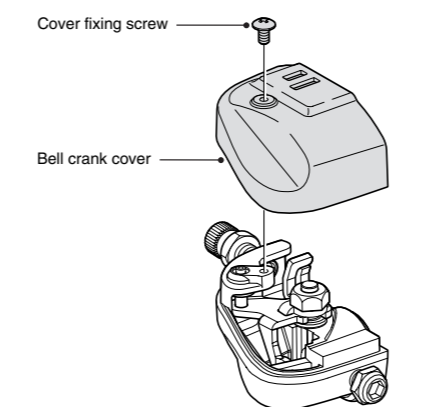

8. Set the inner cable into the link of the main bell crank unit.

- 1) Loosen the inner cable fixing nut on the main bell crank unit. Next, pass the inner cable from the cable adjusting bolt along the groove in the link and then in between the link and the inner cable fixing plate.

Be sure to pass the inner cable through the groove in the link.

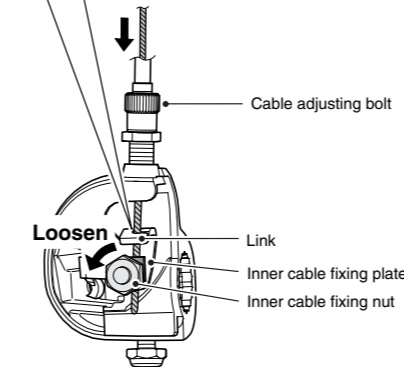
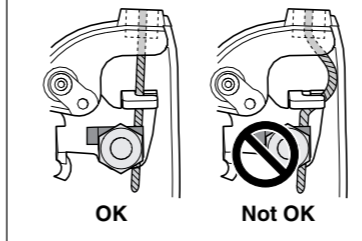

- 2) Set the Revo-shift lever to ②. Next, pull the inner cable so that the edges of the link on the main bell crank unit are between the two white lines on the window, and then tighten the inner cable fixing nut at that position.

Tightening torque:
4 – 6 N·m {40 – 60 kgf·cm}

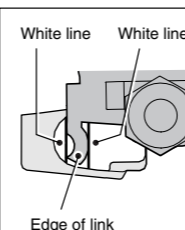
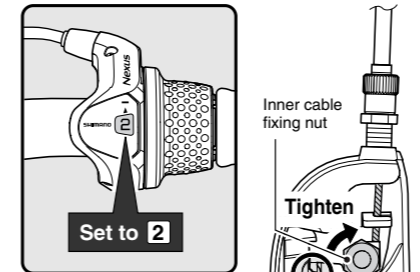

After tightening the inner cable fixing nut, cut off any excess inner cable.

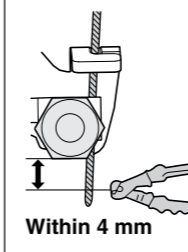

9. Replace the bell crank cover and tighten the cover fixing screw.

Tightening torque:
0.4 – 0.7 N·m {4 – 7 kgf·cm}

Installation of bell crank

1. Insert the push rod into the hub axle.

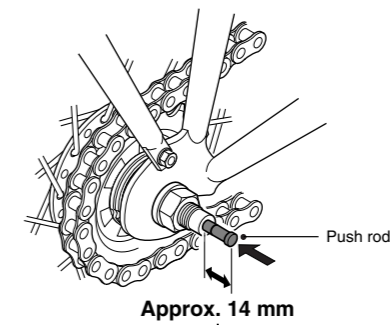

The end of the push rod should project from the end of the hub axle by approximately 14 mm.

2. While pushing the main bell crank unit onto the hub axle, align the serrations inside the main bell crank unit with the hub nut, and then push the main bell crank unit on until it touches the end of the hub axle. In this position, tighten the main unit installation bolt onto the hub axle.

Tightening torque:
3 – 5 N·m {30 – 50 kgf·cm}

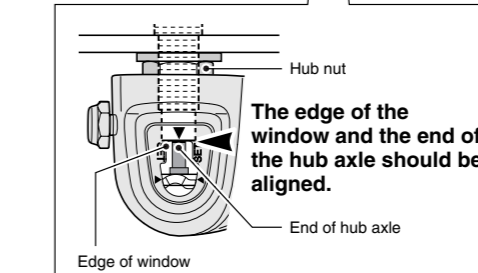
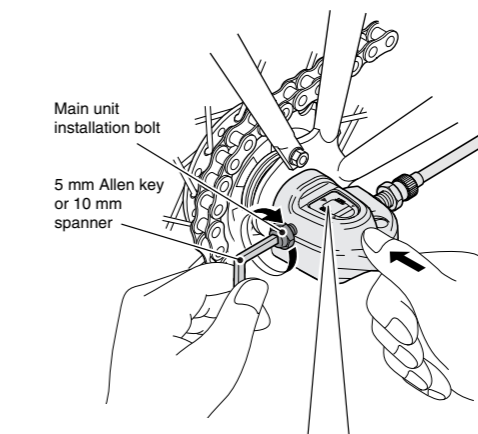

Adjusting bell crank

1. Set the Revo-shift lever to ②. Next, turn the cable adjusting bolt until the red line on the push rod is aligned with the end of the hub axle.

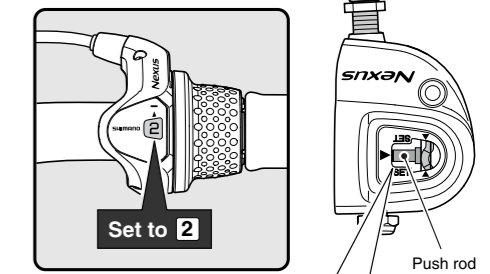

The red line on the push rod and the end of the hub axle should be aligned.

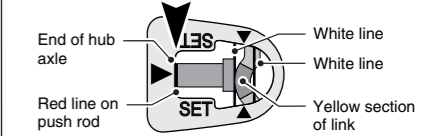

If the red line on the push rod is not visible, adjust so that the yellow section of the link is between the two white lines on the window.

Note:
Look at the two white lines from directly above during adjustment.

2. While turning the crank arm, move the Revo-shift lever from ③ to ① and then from ① back to ③ two or three times to check the gear shifting. Set the Revo-shift lever back to ② and check that the red line on the push rod is aligned with the end of the hub axle.

If they are not aligned, turn the cable adjusting bolt to make fine adjustments.

3. After adjusting the bell crank, tighten the cable adjusting nut to secure the cable adjusting bolt.

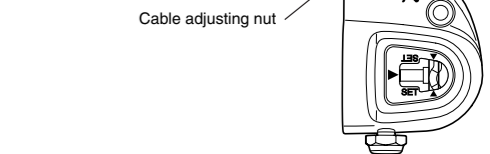

Securing the shifting cable to the frame

Secure the cable to the frame with the outer casing bands.

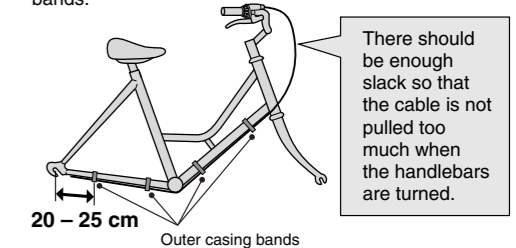

These service instructions explain how to use and maintain the Shimano bicycle parts which have been used on your new bicycle. For any questions regarding your bicycle or other matters which are not related to Shimano parts, please contact the place of purchase or the bicycle manufacturer.

SHIMANO

SHIMANO AMERICAN CORPORATION
One Holland, Irvine, California 92618, U.S.A. Phone: +1-949-951-5003
SHIMANO EUROPE B.V.
Industrieweg 24, 8071 CT Nunspeet, The Netherlands Phone: +31-341-272222
SHIMANO INC.
3-77 Oimatsu-cho, Sakai-ku, Sakai, Osaka 590-8577, Japan