

General Safety Information

⚠ WARNING

- Before use, check the wheels to make sure that there are no bent or loose spokes, dents, scratches or cracks on the rim surface. Do not use the wheel if any of these problems are found.
- If the quick release mechanism is not used correctly, the wheel may come off the bicycle and serious injury could result. Read the Service Instructions for the quick release mechanism thoroughly before use.
- This wheel is designed for use with trekking bikes. If the wheels are used excessively on unpaved surfaces, the wheels may become bent or damaged, and accidents may occur.
- Check that the wheels are fastened securely before riding the bicycle. If the wheels are loose in any way, they may come off the bicycle and serious injury may result.
- Obtain and read the service instructions carefully prior to installing the parts. Loose, worn or damaged parts may cause the bicycle to fall over and serious injury may occur as a result. We strongly recommend only using genuine Shimano replacement parts.
- Read these Technical Service Instructions carefully, and keep them in a safe place for later reference.
- Be sure to read these service instructions in conjunction with the service instructions for the hub dynamo before use.
- Be sure to carefully read the Service Instructions for the disc brakes also.

⚠ CAUTION

- The tires should be inflated to a suitable pressure before use.
- Use rim tape which can withstand high pressures, otherwise the tires may suddenly puncture and come off, and severe injury may result. Furthermore, it is not recommended that you reuse rim tape after it has been removed from the wheel. If the tape is reused, the tires may suddenly puncture and come off, and severe injury may result.

CAUTION

- Use of genuine Shimano spokes and nipples is strongly recommended. If genuine Shimano parts are not used, the hubs or rims may become damaged.
- When using rim brakes, check that there are no pieces of metal or other foreign objects sticking to the brake shoes before riding the bicycle. If any such items are present, they may cause damage to the rim when the brakes are applied.
- When using rim brakes, it is not recommended that you use the brake shoes with the following product names with this product, because severe wearing of the braking surfaces of the rims may occur.
R55HC, M70T3, M70T2, M65T3, M65T, M55T, M50T
Furthermore, do not use brake shoes for carbon rims or ceramic coated rims either.

Note

- Do not apply any oil to the inside of the hub, otherwise the grease will come out and it may cause problems with conductivity.
- We recommend that you ask authorized bicycle dealers to adjust the spoke tensions if there is any initial play in the spokes and after the first 1,000 km of riding.
- The hollow on the other side of the valve from the hole is a guide for indicating the wear of the rim. If this hollow is no longer visible, the rim is at the end of its useful life.
- For maximum performance we highly recommend Shimano lubricants and maintenance products.
- Reflectors (manufactured by CATEYE) are also sold separately. Please ask your bicycle dealer for details.

Model number	Specification	Color
RR-317-WUA/4K SMN03	DIN	Amber
RR-550-WUW/W SMN03	CPSC	White
RR-550-WUA/A SMN03	AS	Amber

- If using a tube with a French valve, install the valve stem adapter that is included.
- Parts are not guaranteed against natural wear or deterioration resulting from normal use.

Technical Service Instructions

SI-0064A-001

WH-S501-V-3D

Front Wheel
(with Hub Dynamo)

In order to realize the best performance, we recommend that the following combination be used.

Applicable tire size	Clincher tire
	700C (28C - 47C)
Rim size	700C (622 X 19C)

Specifications

Model number	WH-S501-V-3D
Rim size	700C (622 X 19C)
Rim width	23.5 mm

Spoke lacing

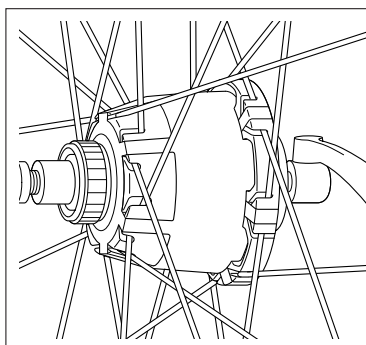

Lace the spokes as shown in the illustration.

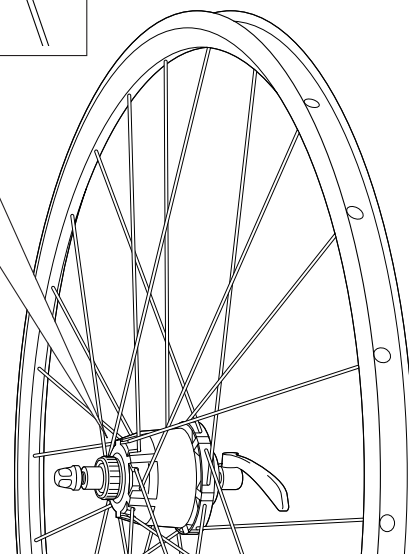

* These values should be used as a guide only.

Spoke tension value	
For front	
Right side	Left side
700 - 1100 N (157 - 247 lbf)	800 - 1200 N (180 - 270 lbf)

SHIMANO

SHIMANO AMERICAN CORPORATION
One Holland, Irvine, California 92618, U.S.A. Phone: +1-949-951-5003

SHIMANO EUROPE B.V.
Industrieweg 24, 8071 CT Nunspeet, The Netherlands Phone: +31-341-272222

SHIMANO INC.
3-77 Oimatsu-cho, Sakai-ku, Sakai-shi, Osaka 590-8577, Japan

Please note: specifications are subject to change for improvement without notice. (English)
© Mar. 2008 by Shimano Inc. XBC SZK Printed in Malaysia.